

For Residential and Commercial Applications

Job Name _____

Contractor _____

Job Location _____

Approval _____

Engineer _____

Contractor's P.O. No. _____

Approval _____

Representative _____

LEAD FREE*

Series LFN45B-M1 Water Pressure Reducing Valves**

Sizes: 1/2" – 1" (15 – 25mm)

Series LFN45B-M1 Water Pressure Reducing Valves are designed to reduce incoming water pressure to a sensible level to protect plumbing system components and reduce water consumption. The LFN45B features Lead Free* construction to comply with Lead Free* installation requirements. This series is suitable for water supply pressures up to 400psi (27.6 bar) and may be adjusted from 25 – 75psi (172 – 517 kPa). The standard setting is 50psi (345 kPa). All parts are quickly and easily serviceable without removing the valve from the line. The standard bypass feature permits the flow of water back through the valve into the main when pressures, due to thermal expansion on the outlet side of the valve, exceed the pressure in the main supply.

Features

- Double union inlet & outlet connections (option DU)
- Integral stainless steel strainer
- Thermoplastic seat & cage
- Lead Free* cast copper silicon alloy body construction
- Serviceable in line
- Bypass feature controls thermal expansion pressure***
- Sealed spring cage on all models for accessible outdoor or pit installations

Models

LFN45B-M1	NPT threaded female inlet x NPT female outlet
LFN45BU-M1	NPT threaded union inlet x NPT female outlet
LFN45BU-S-M1	Solder union inlet x NPT female outlet
LFN45BU-QC-M1	Single Union – QC union inlet
LFN45BDU-M1	Double Union – NPT threaded union female inlet and outlet
LFN45BDU-S-M1	Double Union – Solder union inlet and outlet
LFN45BDU-PEX-M1	Double Union – PEX union inlet and outlet (3/4" and 1" only)
LFN45BDU-CPVC-M1	Double Union – CPVC union inlet and outlet (3/4" and 1" only)
LFN45BDU-QC-M1	Double Union – QC union inlet and outlet (3/4" and 1" only)

Specifications

Standard Specifications: A Water Pressure Reducing Valve with integral strainer shall be installed in the water service pipe near its entrance to the building where supply main pressure exceeds 60psi (413 kPa) to reduce it to 50psi (345 kPa) or lower. The water pressure reducing valve shall be constructed using Lead Free* materials. Lead Free* regulators shall comply with state codes and standards, where applicable, requiring reduced lead content. The valve shall feature a Lead Free* cast copper silicon alloy body suitable for water supply pressures up to 400psi (27.6 bar). Provision shall be made to permit the bypass flow of water back through the valve into the main when pressures, due to thermal expansion on the outlet side of the valve, exceed the pressure in the main supply. Water Pressure Reducing Valve with built-in bypass check valves and integral strainer will be acceptable. Approved valve shall be listed to ASSE 1003 and IAPMO and certified to CSA B356. Valve shall be a Watts Series LFN45B-M1.

Watts product specifications in U.S. customary units and metric are approximate and are provided for reference only. For precise measurements, please contact Watts Technical Service. Watts reserves the right to change or modify product design, construction, specifications, or materials without prior notice and without incurring any obligation to make such changes and modifications on Watts products previously or subsequently sold.

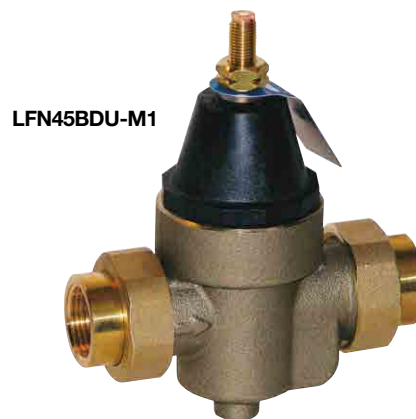

LFN45BDU-M1

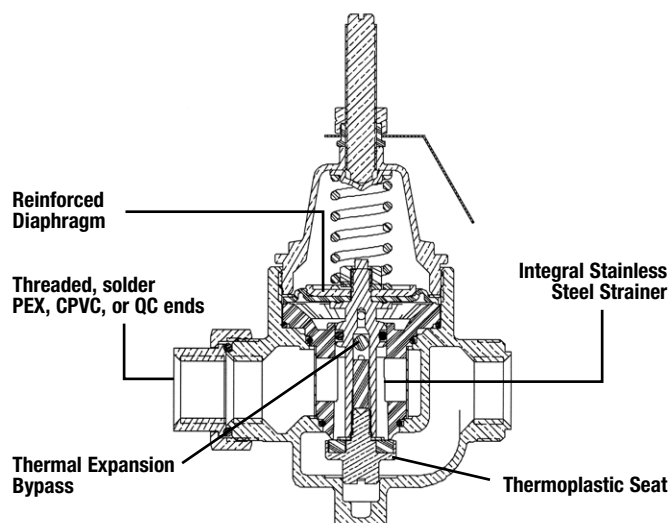

NOTICE

The information contained herein is not intended to replace the full product installation and safety information available or the experience of a trained product installer. You are required to thoroughly read all installation instructions and product safety information before beginning the installation of this product.

*The wetted surface of this product contacted by consumable water contains less than 0.25% of lead by weight.

**A water saving test program concluded that reducing the supply pressure from 80-50psi (551-345 kPa) resulted in a water savings of 30%.

***The bypass feature will not prevent the pressure relief valve from opening on the hot water supply system with pressure above 150psi (10.3 bar).

Materials

Body: Lead Free* cast copper silicon alloy
 Seat: Thermoplastic
 Cage: Thermoplastic
 Integral Strainer: Stainless steel
 Diaphragm: Reinforced EPDM
 Valve Disc: Elastomer

Pressure – Temperature

Temperature Range: 33°F – 180°F (0.5°C – 82°C)
 Maximum Working Pressure: 400psi (27.6 bar)
 Adjustable Reduced Pressure Range: 25 – 75psi (172 – 517 kpa)
 Standard Reduced Pressure Setting: 50psi (345 kpa)

Standards



Meets requirements of ASSE Standard 1003; (ANSI A112.26.2) and CSA Standard B356. Certified by NSF to ANSI/NSF Standard 61 Annex G. Listed by IAPMO and City of Los Angeles.

Capacity

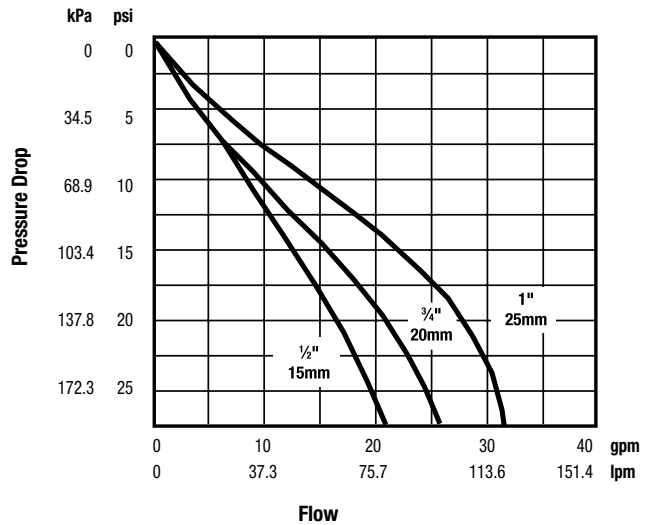

Dimensions – Weights

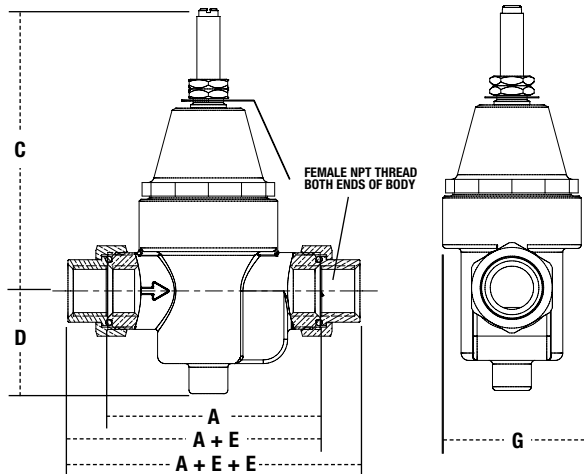

ABOVE VALVE SHOWN WITH SINGLE NPT UNION CONNECTION ON INLET
 VALVES MAY BE ORDERED WITH 0,1,OR 2 UNION CONNECTIONS USING ANY COMBINATION OF NPT, SOLDER, PEX OR CPVC CONNECTIONS REQUIRED
 F DIMENSIONS ARE APPROXIMATE ENGAGEMENT LENGTHS.

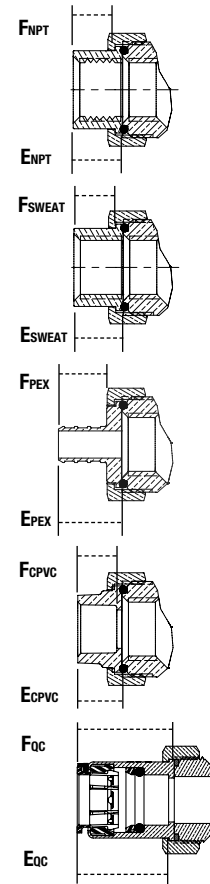

SIZE (DN)		DIMENSIONS										WEIGHT																			
in.	mm	A	C	D	ENPT	ESWEAT	EPEX	ECPVC	Eoc	FNPT	FSWEAT	FPEX	FCPVC	Foc	G	lbs.	kgs.														
1/2	15	3 1/16	88	4 9/16	116	1 11/16	43	3/8	16	3/8	15	1 3/16	21	9/16	15	1 7/16	36	1/2	13	1/2	13	3/8	16	1/2	13	1 1/2	38	2 1/4	57	2	.91
3/4	20	3 3/16	88	4 9/16	116	1 11/16	43	5/8	16	7/8	21	1 5/16	24	1 3/16	21	1 9/16	40	9/16	14	3/4	19	5/8	16	3/4	18	1 11/16	42	2 1/4	57	2	.91
1	25	4 1/8	105	4 9/16	116	1 11/16	43	3/4	20	1	26	1 1/8	29	1 1/16	26	1 11/16	43	1 1/16	17	1 5/16	23	1 3/16	21	1 5/16	23	1 3/4	45	2 1/4	57	3	1.36



USA: Tel: (978) 689-6066 • Fax: (978) 975-8350 • Watts.com

Canada: Tel: (905) 332-4090 • Fax: (905) 332-7068 • Watts.com

Latin America: Tel: (52) 81-1001-8600 • Fax: (52) 81-8000-7091 • Watts.com