

ITEM NO.	PART NUMBER	DESCRIPTION
1	300500	ASSEMBLY, CASE, CHART DWG
2	300200	DEFLECTOR, BB, F SERIES, CHART DWG
3	302212	REPL ELMT FINNED, 2F 500W 120V
	302213	REPL ELMT FINNED, 3F 750W 120V
	302214	REPL ELMT FINNED, 4F 1000W 120V
	302216	REPL ELMT FINNED, 6F 1500W 120V
	302201	REPL ELMT FINNED, 2F 350W 240V
	302202	REPL ELMT FINNED, 2.5F 500W 240V
	302203	REPL ELMT FINNED, 3F 750W 240V
	302204	REPL ELMT FINNED, 4F 1000W 240V
	302205	REPL ELMT FINNED, 5F 1250W 240V
	302206	REPL ELMT FINNED, 6F 1500W 240V
	302208	REPL ELMT FINNED, 8F 2000W 240V
	302210	REPL ELMT FINNED, 8F 2500W 240V
	302226	REPL ELMT FINNED, 8F2025 2000/2500W 240V
	302209	REPL ELMT FINNED, 10F 2500W 240V
	302218	REPL ELMT FINNED, 2.5F 500W 208V
	302219	REPL ELMT FINNED, 3F 750W 208V
	302220	REPL ELMT FINNED, 4F 1000W 208V
	302221	REPL ELMT FINNED, 5F 1250W 208V
	302222	REPL ELMT FINNED, 6F 1500W 208V
	302224	REPL ELMT FINNED, 5F 2000W 208V
	302225	REPL ELMT FINNED, 8F 2500W 208V
4	---	BUSHING NYLON 3/8 ELEMENT
5	050312	10H CAPILLARY LIMIT CHART DWG
	050311	LIMIT 2.5F500
	050312	LIMIT 3F750
	050313	LIMIT 4F1000
	050314	LIMIT 5F1250
	050315	LIMIT 6F1500
	050317	LIMIT 8F2000/8F2500
	050318	LIMIT 10F2500
6	300301	F SERIES, COVER, BB
	300302	COVER 2.5F (30") ALMOND
	300303	COVER 3F ALMOND
	300304	COVER 4F ALMOND
	300305	COVER 5F ALMOND
	300306	COVER 6F ALMOND
	300308	COVER 8F ALMOND
	300309	COVER 10F ALMOND
	300310	COVER 2F (24") WHITE
	300311	COVER 2.5F (30") WHITE
	300312	COVER 3F WHITE
	300313	COVER 4F WHITE
	300314	COVER 5F WHITE
	300315	COVER 6F WHITE
	300317	COVER 8F WHITE
	300318	COVER 10F WHITE
7	300701	PLATE END, EMBOSSED, ALMOND
	300702	PLATE END, EMBOSSED, WHITE
8	14910	BTF1A BB STAT SP ALMOND
	14915	BTF1W BB STAT SP WHITE
	14920	BTF2A BB STAT DP ALMOND
	14925	BTF2W BB STAT DP WHITE
9	051211	STAT 58T1 SP; BTF1, C, CS, CTT1
	051206	STAT 58T2 DP; BTF2,CTT2,UCT2,EBK
10	300704	PLATE STAT BTF ALMOND
	300705	PLATE STAT BTF WHITE
11	040046	KNOB BTF1A / UPTA SP ALMOND
	040038	KNOB BTF1W / UPTW SP WHITE
	040047	KNOB BTF2 DP ALMOND
	040039	KNOB BTF2 DP WHITE

ELECTRIC BASEBOARD PARTS & ASSEMBLY DETAIL VIEW

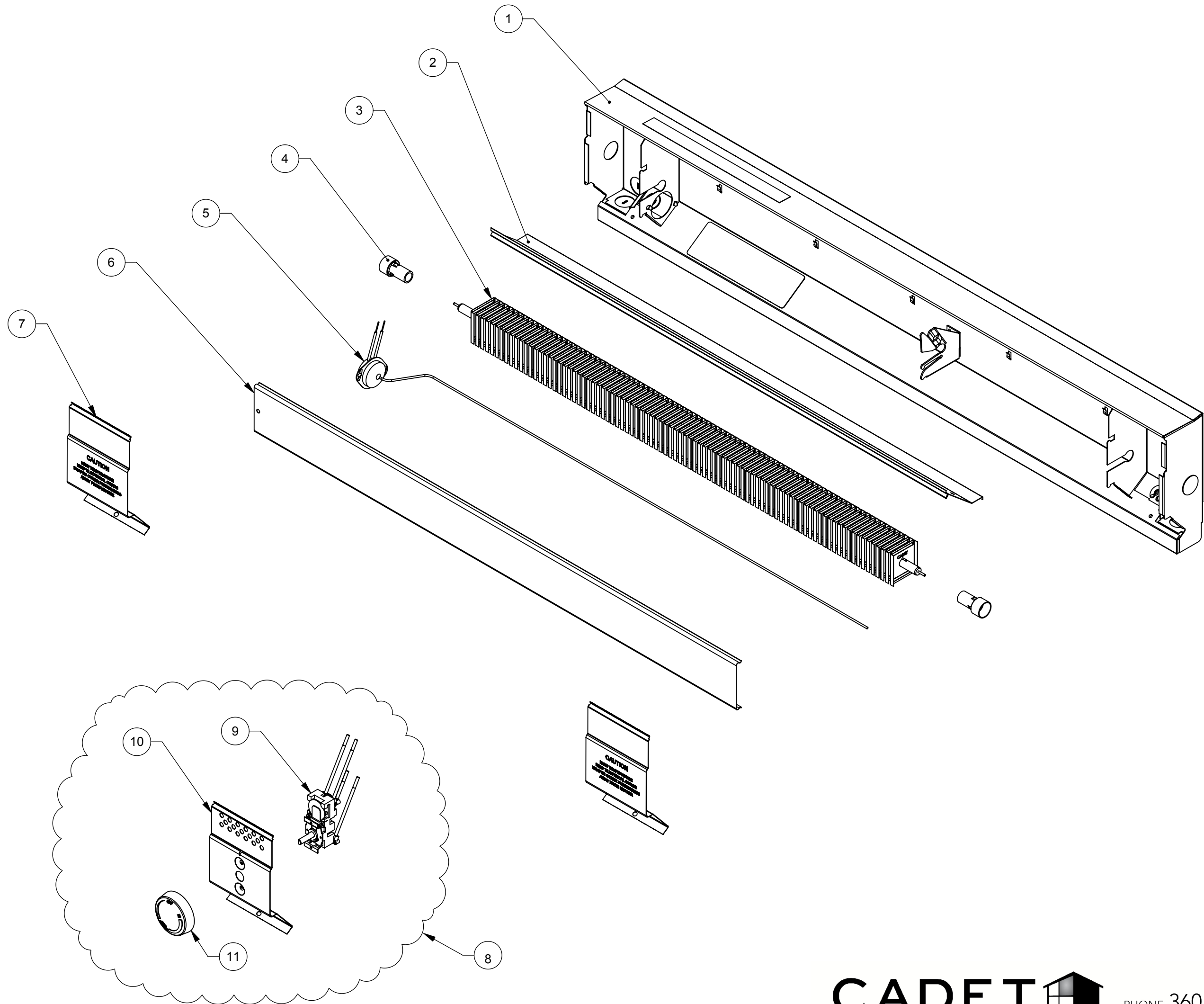

REVISIONS					
ECN #	REV.	DESCRIPTION	DATE	DRAWN BY:	APPROVED
2434	A	BABSEBOARD F SERIES ASSEMBLY EXPLODED VIEW	10/20/2014	E.YANCHUK	G.RALSTIN
2550	B	REMOVED AMP RATING FROM STAT DESCRIPTION	2/16/2016	G.RALSTIN	D.CRACIUN

CADET PHONE 360.693.2505
 INVITING WARMTH www.cadetheat.com

For verification of exact diagram for your heater, contact Cadet's Technical Department

INTERPRET GEOMETRIC TOLERANCE PER: ASME Y14.5M	NAME	DATE	CADET MANUFACTURING COMPANY VANCOUVER, WA. U.S.A TEL. (360) 693-2505	
DIMENSIONS ARE IN INCHES DIMENSIONS IN [] ARE MM	DRAWN	E.Y.		10/20/2014
TOLERANCES UNLESS OTHERWISE SPECIFIED	CHECKED			
ANGULAR: ±1°	ENG APP.		DESCRIPTION:	
INCHES			ELECTRIC BASEBOARD PARTS & ASSEMBLY DETAIL VIEW	
.x ±.062	MATERIAL		SIZE DWG. NO.	
.xx ±.030			C 990012	
.xxx ±.015	FINISH		REV	
.xxxx ±.008			B	
			SCALE: 1:4	
			990012.slddrw	
			SHEET 1 OF 1	
			DO NOT SCALE DRAWING	

THE DOCUMENT IS THE PROPERTY OF CADET MANUFACTURING COMPANY AND MAY CONTAIN PROPRIETARY INFORMATION. BY ACCEPTING THIS INFORMATION, THE BORROWER AGREES THAT IT WILL NOT BE USED FOR ANY PURPOSE OTHER THAN FOR WHICH IT IS LOANED. IT MAY NOT BE REPRODUCED IN ANY MANNER AND SHOULD BE DESTROYED AFTER SERVING ITS INTENDED FUNCTION.